



PAL Series 3-Phase

0.4kW

■ SPECIFICATION

■ MOTOR

Output (kW)	Model Name	Poles	Voltage (V)	Freq. (Hz)	Rated Load			Duty	Degrees of protection	Insulation Classification	Protective Cooling System
					Current (A)	Speed (r/min)	Efficiency (%)				
0.4	PAL□-□-M□040R4□	4	220/380	60	2,00/1,20	1730	74,1	CONT.	IP55	F	Totally Enclosed Fan-Cooled
	PAL□-□-M□040W6□	4	200	50	2,20	1450	74,2				
			200/220	60	1,80/1,90	1735/1745	76,4/75,7				
	PAL□-□-M□040X6□	4	380/400	50	1,10/1,10	1425/1430	75,5/74,1				
			400/440	60	1,00/1,00	1710/1725	75,4/75,2				

- The Brake Geared Motor is divided into 2 models: one is a non-water proof product with IP40 while the other is a waterproof product with IP55.
- The Models with IP40 and IP55 have the same electric characteristics.

■ GEARED MOTOR – 50Hz

Frame No.	22					28						32				
Reduction gear ratio	5	10	15	20	25	30	40	50	60	80	★100	100	120	160	200	
Rotation speed (r/min)	300	150	100	75	60	50	37,5	30	25	18,8	15	15	12,5	9,4	7,5	
Allowable torque	kgf · m	1,2	2,5	3,7	4,9	6,2	7,4	9,6	11,9	14,3	19,1	19,7	23,9	28,7	38,2	44
	N · m	12	25	36	48	61	73	94	117	140	187	193	234	281	374	431
Allowable O.H.L	kgf	90	120	140	150	170	260	290	320	350	350	350	500	600	600	600
	N	882	1180	1370	1470	1670	2550	2840	3140	3430	3430	3430	4900	5880	5880	5880

■ GEARED MOTOR – 60Hz

Frame No.	22					28						32				
Reduction gear ratio	5	10	15	20	25	30	40	50	60	80	★100	100	120	160	200	
Rotation speed (r/min)	360	180	120	90	72	60	45	36	30	22,5	18	18	15	11,2	9	
Allowable torque	kgf · m	1	2,1	3,1	4,1	5,1	6,2	8	10	11,9	15,9	16,4	19,9	23,9	31,9	39,8
	N · m	10	21	30	40	50	61	78	98	117	156	161	195	234	313	390
Allowable O.H.L	kgf	90	120	140	150	170	260	290	320	350	350	350	500	600	600	600
	N	882	1180	1370	1470	1670	2550	2840	3140	3430	3430	3430	4900	5880	5880	5880

- Note) • Permissible O.H.L (allowable overhung load) is based on the central part of the outlet length for output shaft
 • Permissible Torque is limited for products with a mark "★" of reduction gear ratio
 • ■ Color indicates the same direction of motor rotation, while other color indicates the opposite direction of motor rotation.

Model Name Coding
 36Page

Specification for output shaft
 70Page

Technological Data
 101Page

■ PAL TYPE DIMENSIONS [Lead wire Box Type]

UNIT = mm

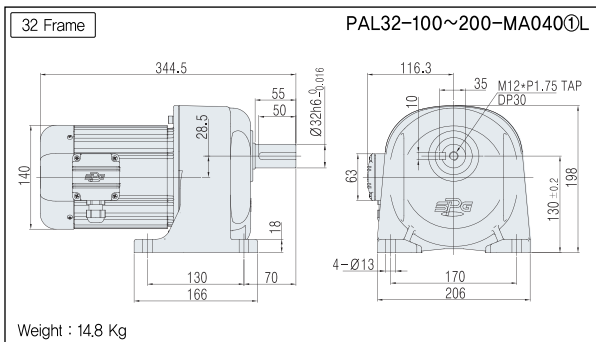
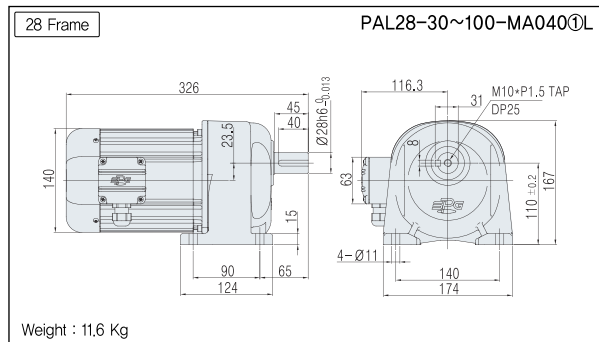
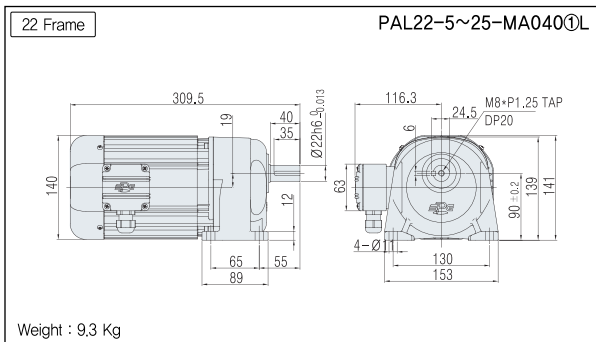

- Model type ① : Power (Voltage & Frequency)
- Lead wire Box for 0.2~0.75kW

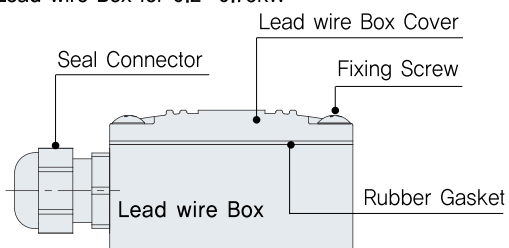

■ PAL TYPE DIMENSIONS [Terminal Box Type]

- Note) • Dimensions for IP40 model and IP55 model are the same.
 • The brake-attached model is applied to the Terminal Box Type for basic features, but does not apply to the lead wire box type.
 • () dimension and weight in dimensions is for brake attached model specification

UNIT = mm

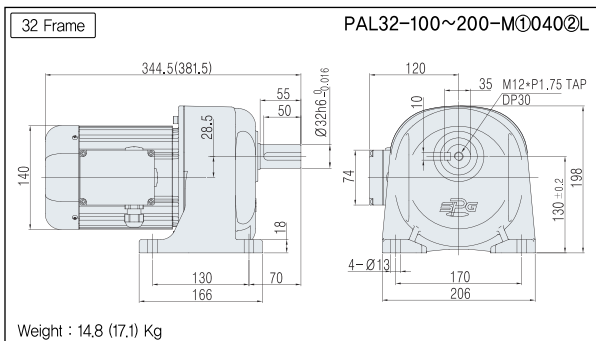
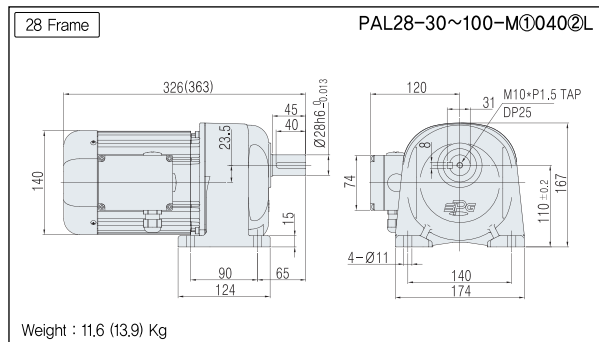
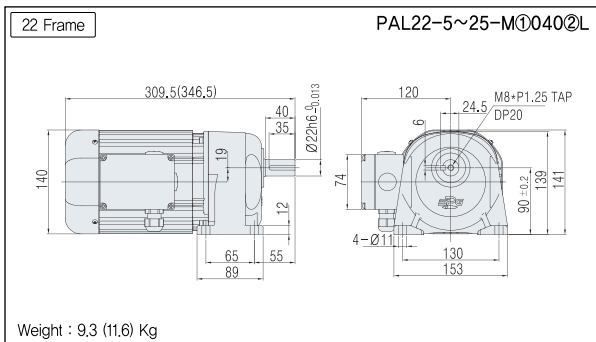

- Model type ① : Motor option (B, C, D)
- ② : Power (Voltage & Frequency)
- Terminal Box for 0.2~0.75kW

